

- 技术要求:
- 1.材质: PC.
  - 2.表面处理: 本色白.
  - 3.产品未注圆角与拔模斜度按3D.
  - 4."\*"标记为重点控制尺寸.
  - 5.未注公差按GB/T14486-2008-MT6.
  - 6.产品外观按《N-SOP-ED-24 塑胶类产品检验指导书》.

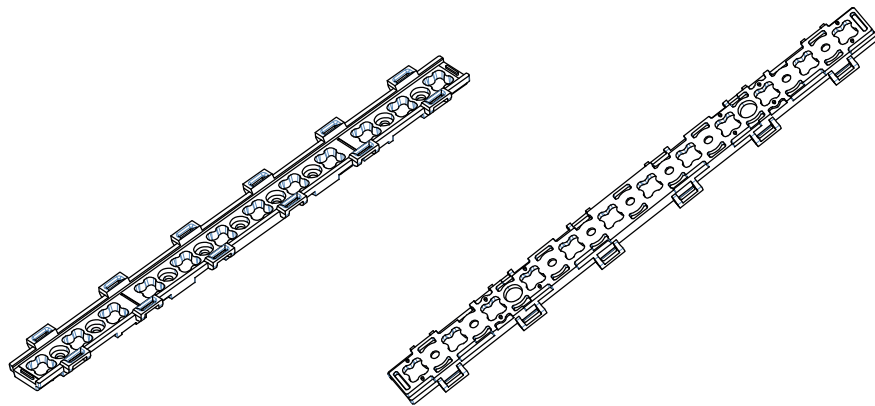

					<b>Nata</b> <sup>®</sup>		版本 VERSIONS
							K-
					产品编码 PRODUCT CODE	92.70.293.00	
					产品名称 PRODUCT NAME	12-0071-HOLDER	
					客户代号 CUSTOMER ID	NT	
					客户编号 CUSTOMER CODE	FK-W35@12in1 HOLDER	
标记 MARK	处数 NO.OF MODIF	更改内容 MODIFICATIONS		签名 SIGNED BY	更改日期 MODIF. DATE		
设计 DESIGNER		制图 DRAWN BY		比例 SCALE	1:1		
工艺 TECHNICAN		审核 CHECKED BY		视角 1st ANGLE PROJECTION			
批准 APPROVED BY		日期 DATE(DD-MM-YYYY)	21-04-2021	页数 PAGE	SHEET 1 OF 1		
					产品图 PRODUCT DRAWING		单位 UNIT mm